

2022

AP[®]

 CollegeBoard

AP[®] Physics 2: Algebra-Based Free-Response Questions

AP[®] PHYSICS 2 TABLE OF INFORMATION

CONSTANTS AND CONVERSION FACTORS

Proton mass, $m_p = 1.67 \times 10^{-27}$ kg Neutron mass, $m_n = 1.67 \times 10^{-27}$ kg Electron mass, $m_e = 9.11 \times 10^{-31}$ kg Avogadro's number, $N_0 = 6.02 \times 10^{23}$ mol ⁻¹ Universal gas constant, $R = 8.31$ J/(mol·K) Boltzmann's constant, $k_B = 1.38 \times 10^{-23}$ J/K	Electron charge magnitude, $e = 1.60 \times 10^{-19}$ C 1 electron volt, $1 \text{ eV} = 1.60 \times 10^{-19}$ J Speed of light, $c = 3.00 \times 10^8$ m/s Universal gravitational constant, $G = 6.67 \times 10^{-11}$ m ³ /kg·s ² Acceleration due to gravity at Earth's surface, $g = 9.8$ m/s ²
1 unified atomic mass unit, Planck's constant, Vacuum permittivity, Coulomb's law constant, $k = 1/4\pi\epsilon_0 = 9.0 \times 10^9$ N·m ² /C ² Vacuum permeability, Magnetic constant, $k' = \mu_0/4\pi = 1 \times 10^{-7}$ (T·m)/A 1 atmosphere pressure,	$1 \text{ u} = 1.66 \times 10^{-27}$ kg = 931 MeV/c ² $h = 6.63 \times 10^{-34}$ J·s = 4.14 × 10 ⁻¹⁵ eV·s $hc = 1.99 \times 10^{-25}$ J·m = 1.24 × 10 ³ eV·nm $\epsilon_0 = 8.85 \times 10^{-12}$ C ² /N·m ² $\mu_0 = 4\pi \times 10^{-7}$ (T·m)/A $1 \text{ atm} = 1.0 \times 10^5$ N/m ² = 1.0 × 10 ⁵ Pa

UNIT SYMBOLS	meter, m	mole, mol	watt, W	farad, F
	kilogram, kg	hertz, Hz	coulomb, C	tesla, T
	second, s	newton, N	volt, V	degree Celsius, °C
	ampere, A	pascal, Pa	ohm, Ω	electron volt, eV
	kelvin, K	joule, J	henry, H	

PREFIXES		
Factor	Prefix	Symbol
10 ¹²	tera	T
10 ⁹	giga	G
10 ⁶	mega	M
10 ³	kilo	k
10 ⁻²	centi	c
10 ⁻³	milli	m
10 ⁻⁶	micro	μ
10 ⁻⁹	nano	n
10 ⁻¹²	pico	p

VALUES OF TRIGONOMETRIC FUNCTIONS FOR COMMON ANGLES							
θ	0°	30°	37°	45°	53°	60°	90°
$\sin \theta$	0	1/2	3/5	$\sqrt{2}/2$	4/5	$\sqrt{3}/2$	1
$\cos \theta$	1	$\sqrt{3}/2$	4/5	$\sqrt{2}/2$	3/5	1/2	0
$\tan \theta$	0	$\sqrt{3}/3$	3/4	1	4/3	$\sqrt{3}$	∞

The following conventions are used in this exam.

- I. The frame of reference of any problem is assumed to be inertial unless otherwise stated.
- II. In all situations, positive work is defined as work done on a system.
- III. The direction of current is conventional current: the direction in which positive charge would drift.
- IV. Assume all batteries and meters are ideal unless otherwise stated.
- V. Assume edge effects for the electric field of a parallel plate capacitor unless otherwise stated.
- VI. For any isolated electrically charged object, the electric potential is defined as zero at infinite distance from the charged object

AP[®] PHYSICS 2 EQUATIONS

MECHANICS

$$v_x = v_{x0} + a_x t$$

$$x = x_0 + v_{x0} t + \frac{1}{2} a_x t^2$$

$$v_x^2 = v_{x0}^2 + 2a_x(x - x_0)$$

$$\vec{a} = \frac{\sum \vec{F}}{m} = \frac{\vec{F}_{net}}{m}$$

$$|\vec{F}_f| \leq \mu |\vec{F}_n|$$

$$a_c = \frac{v^2}{r}$$

$$\vec{p} = m\vec{v}$$

$$\Delta\vec{p} = \vec{F} \Delta t$$

$$K = \frac{1}{2} m v^2$$

$$\Delta E = W = F_{\parallel} d = F d \cos \theta$$

$$P = \frac{\Delta E}{\Delta t}$$

$$\theta = \theta_0 + \omega_0 t + \frac{1}{2} \alpha t^2$$

$$\omega = \omega_0 + \alpha t$$

$$x = A \cos(\omega t) = A \cos(2\pi f t)$$

$$x_{cm} = \frac{\sum m_i x_i}{\sum m_i}$$

$$\vec{\alpha} = \frac{\sum \vec{\tau}}{I} = \frac{\vec{\tau}_{net}}{I}$$

$$\tau = r_{\perp} F = r F \sin \theta$$

$$L = I \omega$$

$$\Delta L = \tau \Delta t$$

$$K = \frac{1}{2} I \omega^2$$

$$|\vec{F}_s| = k |\vec{x}|$$

a = acceleration
 A = amplitude
 d = distance
 E = energy
 F = force
 f = frequency
 I = rotational inertia
 K = kinetic energy
 k = spring constant
 L = angular momentum
 ℓ = length
 m = mass
 P = power
 p = momentum
 r = radius or separation
 T = period
 t = time
 U = potential energy
 v = speed
 W = work done on a system
 x = position
 y = height
 α = angular acceleration
 μ = coefficient of friction
 θ = angle
 τ = torque
 ω = angular speed

$$U_s = \frac{1}{2} k x^2$$

$$\Delta U_g = m g \Delta y$$

$$T = \frac{2\pi}{\omega} = \frac{1}{f}$$

$$T_s = 2\pi \sqrt{\frac{m}{k}}$$

$$T_p = 2\pi \sqrt{\frac{\ell}{g}}$$

$$|\vec{F}_g| = G \frac{m_1 m_2}{r^2}$$

$$\vec{g} = \frac{\vec{F}_g}{m}$$

$$U_G = -\frac{G m_1 m_2}{r}$$

ELECTRICITY AND MAGNETISM

$$|\vec{F}_E| = \frac{1}{4\pi\epsilon_0} \frac{|q_1 q_2|}{r^2}$$

$$\vec{E} = \frac{\vec{F}_E}{q}$$

$$|\vec{E}| = \frac{1}{4\pi\epsilon_0} \frac{|q|}{r^2}$$

$$\Delta U_E = q \Delta V$$

$$V = \frac{1}{4\pi\epsilon_0} \frac{q}{r}$$

$$|\vec{E}| = \left| \frac{\Delta V}{\Delta r} \right|$$

$$\Delta V = \frac{Q}{C}$$

$$C = \kappa \epsilon_0 \frac{A}{d}$$

$$E = \frac{Q}{\epsilon_0 A}$$

$$U_C = \frac{1}{2} Q \Delta V = \frac{1}{2} C (\Delta V)^2$$

$$I = \frac{\Delta Q}{\Delta t}$$

$$R = \frac{\rho \ell}{A}$$

$$P = I \Delta V$$

$$I = \frac{\Delta V}{R}$$

$$R_s = \sum_i R_i$$

$$\frac{1}{R_p} = \sum_i \frac{1}{R_i}$$

$$C_p = \sum_i C_i$$

$$\frac{1}{C_s} = \sum_i \frac{1}{C_i}$$

$$B = \frac{\mu_0 I}{2\pi r}$$

A = area
 B = magnetic field
 C = capacitance
 d = distance
 E = electric field
 \mathcal{E} = emf
 F = force
 I = current
 ℓ = length
 P = power
 Q = charge
 q = point charge
 R = resistance
 r = separation
 t = time
 U = potential (stored) energy
 V = electric potential
 v = speed
 κ = dielectric constant
 ρ = resistivity
 θ = angle
 Φ = flux

$$\vec{F}_M = q\vec{v} \times \vec{B}$$

$$|\vec{F}_M| = |q\vec{v}| |\sin \theta| |\vec{B}|$$

$$\vec{F}_M = I\vec{\ell} \times \vec{B}$$

$$|\vec{F}_M| = |I\vec{\ell}| |\sin \theta| |\vec{B}|$$

$$\Phi_B = \vec{B} \cdot \vec{A}$$

$$\Phi_B = |\vec{B}| \cos \theta |\vec{A}|$$

$$\mathcal{E} = -\frac{\Delta \Phi_B}{\Delta t}$$

$$\mathcal{E} = B \ell v$$

AP[®] PHYSICS 2 EQUATIONS

FLUID MECHANICS AND THERMAL PHYSICS

$$\rho = \frac{m}{V}$$

$$P = \frac{F}{A}$$

$$P = P_0 + \rho gh$$

$$F_b = \rho Vg$$

$$A_1 v_1 = A_2 v_2$$

$$P_1 + \rho g y_1 + \frac{1}{2} \rho v_1^2 = P_2 + \rho g y_2 + \frac{1}{2} \rho v_2^2$$

$$\frac{Q}{\Delta t} = \frac{kA \Delta T}{L}$$

$$PV = nRT = Nk_B T$$

$$K = \frac{3}{2} k_B T$$

$$W = -P \Delta V$$

$$\Delta U = Q + W$$

A = area
 F = force
 h = depth
 k = thermal conductivity
 K = kinetic energy
 L = thickness
 m = mass
 n = number of moles
 N = number of molecules
 P = pressure
 Q = energy transferred to a system by heating
 T = temperature
 t = time
 U = internal energy
 V = volume
 v = speed
 W = work done on a system
 y = height
 ρ = density

WAVES AND OPTICS

$$\lambda = \frac{v}{f}$$

$$n = \frac{c}{v}$$

$$n_1 \sin \theta_1 = n_2 \sin \theta_2$$

$$\frac{1}{s_i} + \frac{1}{s_o} = \frac{1}{f}$$

$$|M| = \left| \frac{h_i}{h_o} \right| = \left| \frac{s_i}{s_o} \right|$$

$$\Delta L = m \lambda$$

$$d \sin \theta = m \lambda$$

d = separation
 f = frequency or focal length
 h = height
 L = distance
 M = magnification
 m = an integer
 n = index of refraction
 s = distance
 v = speed
 λ = wavelength
 θ = angle

GEOMETRY AND TRIGONOMETRY

Rectangle
 $A = bh$

Triangle
 $A = \frac{1}{2} bh$

Circle
 $A = \pi r^2$
 $C = 2\pi r$

Rectangular solid
 $V = \ell wh$

Cylinder
 $V = \pi r^2 \ell$
 $S = 2\pi r \ell + 2\pi r^2$

Sphere
 $V = \frac{4}{3} \pi r^3$
 $S = 4\pi r^2$

A = area
 C = circumference
 V = volume
 S = surface area
 b = base
 h = height
 ℓ = length
 w = width
 r = radius

Right triangle
 $c^2 = a^2 + b^2$
 $\sin \theta = \frac{a}{c}$
 $\cos \theta = \frac{b}{c}$
 $\tan \theta = \frac{a}{b}$

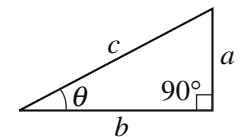

MODERN PHYSICS

$$E = hf$$

$$K_{\max} = hf - \phi$$

$$\lambda = \frac{h}{p}$$

$$E = mc^2$$

E = energy
 f = frequency
 K = kinetic energy
 m = mass
 p = momentum
 λ = wavelength
 ϕ = work function

Begin your response to **QUESTION 1** on this page.**PHYSICS 2****SECTION II****Time—1 hour and 30 minutes****4 Questions**

Directions: Questions 1 and 4 are short free-response questions that require about 20 minutes each to answer and are worth 10 points each. Questions 2 and 3 are long free-response questions that require about 25 minutes each to answer and are worth 12 points each. Show your work for each part in the space provided after that part.

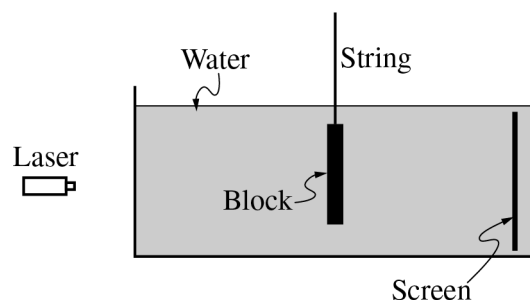

1. (10 points, suggested time 20 minutes)

Students are investigating electromagnetic wave phenomena in transparent media. They use a string to support a stationary thin, rectangular block of mass m_b , volume V_b , and density ρ_b . The block has two narrow slits in its center and is submerged in a glass tank containing water with density ρ_w , as shown above.

GO ON TO THE NEXT PAGE.

Continue your response to **QUESTION 1** on this page.

(a)

i. On the dot below, which represents the block, draw and label the forces that are exerted on the block. Each force must be represented by a distinct arrow starting on, and pointing away from, the dot.



ii. Derive an expression for the force exerted on the block by the string in terms of the given quantities and physical constants, as appropriate.

GO ON TO THE NEXT PAGE.

Continue your response to **QUESTION 1** on this page.

- (b) A monochromatic laser beam is incident perpendicular to the wall of the tank. The beam passes through the slits in the block. An interference pattern is formed on the screen inside the tank. The water is then replaced with a clear fluid with a greater index of refraction than that of water. In a coherent, paragraph-length response, describe how the greater index of refraction of the new fluid affects the interference pattern. Explain your reasoning in terms of speed, frequency, and wavelength of the light.

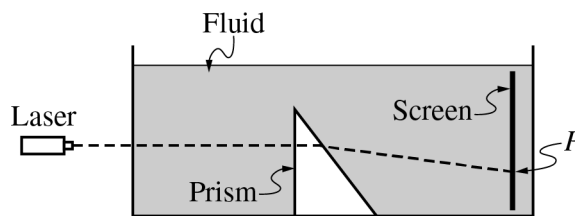

- (c) The block is replaced by a triangular prism, as shown above. The path of the beam is indicated by the dotted line, and the beam reaches the screen at point *P*. The fluid is then removed from the tank, and the prism is surrounded by air. Predict whether the beam will reach the side of the tank above point *P*, at point *P*, or below point *P* when the prism is surrounded by air. Support your answer using physics principles.

GO ON TO THE NEXT PAGE.

Begin your response to **QUESTION 2** on this page.

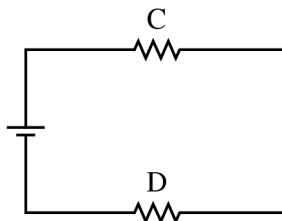
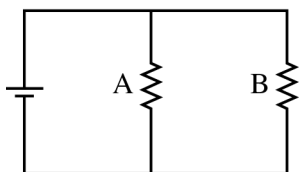

2. (12 points, suggested time 25 minutes)

Students perform an experiment with a battery and four resistors, A, B, C, and D. The resistance of resistors A and C is $R_A = R_C = R$. The resistance of resistors B and D is $R_B = R_D = 2R$. The students create the two circuits shown above and measure the potential differences ΔV_A , ΔV_B , ΔV_C , and ΔV_D across resistors A, B, C, and D, respectively.

(a) From greatest to least, rank the magnitudes of the potential differences across the resistors. Use “1” for the greatest magnitude, “2” for the next greatest magnitude, and so on. If any potential differences have the same magnitude, use the same number for their ranking.

___ ΔV_A ___ ΔV_B ___ ΔV_C ___ ΔV_D

Justify your answer.

In another experiment, the students have a capacitor with unknown capacitance C_U . They want to determine C_U by using a battery of potential difference 4.5 V and several other capacitors of known capacitance. They create circuits with the battery, the unknown capacitor, and one of the capacitors of known capacitance. The students wait until the capacitors are fully charged and then record the potential difference ΔV_{known} across the known capacitor and the potential difference ΔV_U across the unknown capacitor. Their data are shown in the table on the following page.

GO ON TO THE NEXT PAGE.

Continue your response to **QUESTION 2** on this page.

Known Capacitance of Capacitors (μF)	ΔV_{known} (V)	ΔV_{U} (V)		
200	0.91	3.53		
300	0.65	3.74		
400	0.51	3.95		
500	0.42	4.06		
600	0.36	4.17		

- (b)
- Calculate the amount of charge on the capacitor of known capacitance of $200 \mu\text{F}$ in the students' experiment.
 - Briefly explain why the data in the table provide evidence that the capacitors are connected in series.
 - Briefly explain why connecting the capacitors in parallel would not provide enough information to determine the capacitance of the unknown capacitor if the only measuring device available is a voltmeter.

GO ON TO THE NEXT PAGE.

Continue your response to **QUESTION 2** on this page.

- (c) The students want to produce a linear graph of the data so that the capacitance C_U of the unknown capacitor can be determined from the slope of the best-fit line for the data.
- i. Indicate two quantities that could be plotted to produce the desired graph. Use the empty columns of the data table in part (b) to record any values that you need to calculate.

Vertical axis _____ Horizontal axis _____

- ii. Label the axes below and provide an appropriate scale with units. Plot the data points for the quantities indicated in part (c)(i) on the axes and draw a best-fit line.

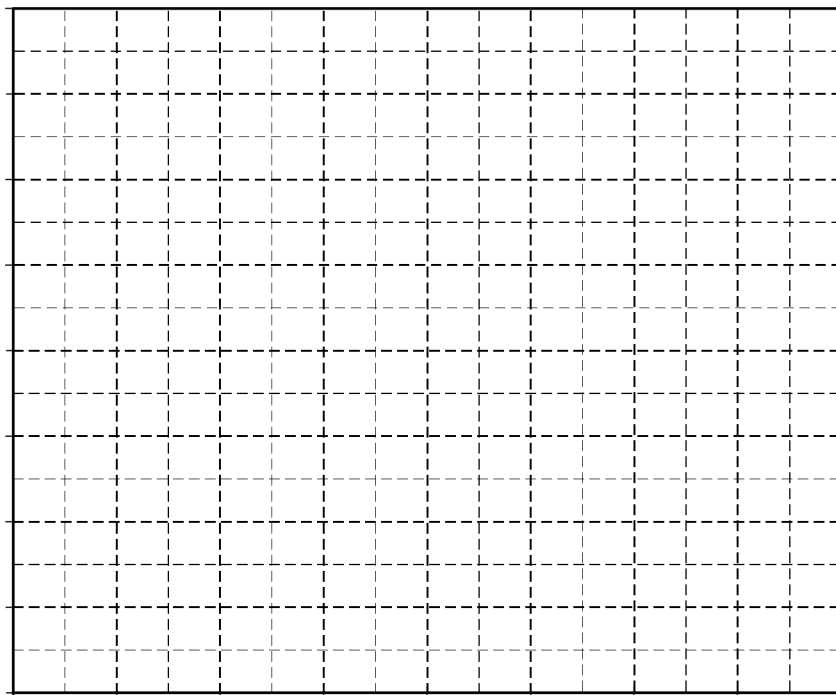

- iii. Using your best-fit line, determine the capacitance of capacitor C_U .

GO ON TO THE NEXT PAGE.

Begin your response to **QUESTION 3** on this page.

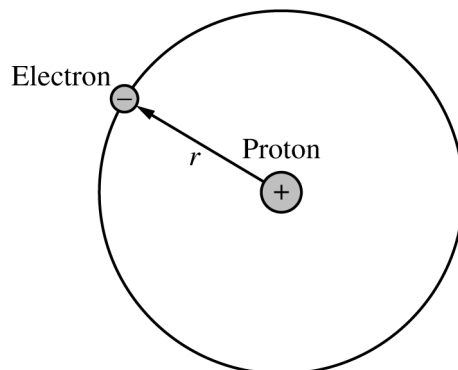

Note: Figure not drawn to scale.

3. (12 points, suggested time 25 minutes)

A hydrogen atom can be modeled as an electron in a circular orbit of radius r about a stationary proton, as shown above. The gravitational force between the proton and electron is negligible compared to the electrostatic force between them.

(a) Derive an equation for the speed v of the electron in terms of r and physical constants, as appropriate.

(b) Derive an equation for the total energy of the atom in terms of r and physical constants, as appropriate.

GO ON TO THE NEXT PAGE.

Continue your response to **QUESTION 3** on this page.

- (c) When the hydrogen atom absorbs a photon, the electron moves to an orbit with a larger radius and the total energy of the atom increases. Is your equation for the energy derived in part (b) consistent with this description of the model of a hydrogen atom absorbing a photon? Explain why the equation is or is not consistent.
- (d) Experiments show that a hydrogen atom can absorb a photon of frequency 3.2×10^{15} Hz.
- Calculate the energy of a photon with this frequency.
 - A student claims that when a hydrogen atom absorbs a photon at this frequency, the energy could be converted into mass, adding an electron to the atom. Calculate the amount of energy needed to create a particle with the mass of an electron and determine whether or not there is sufficient energy gained by the atom to add another electron.

GO ON TO THE NEXT PAGE.

Continue your response to **QUESTION 3** on this page.

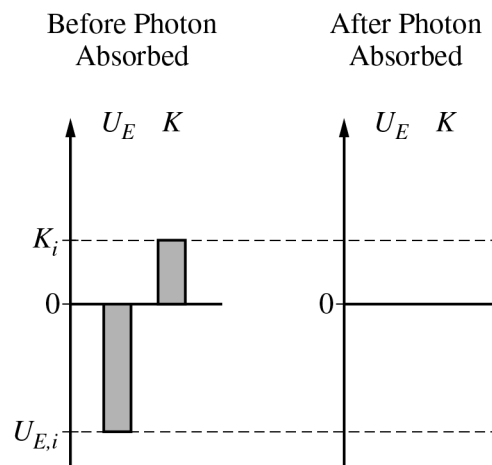

iii. The left bar chart in the figure above is complete and represents the initial electric potential energy $U_{E,i}$ of the atom and the initial kinetic energy K_i of the electron before the photon is absorbed. In the space provided on the right, draw a bar chart to represent a possible final electric potential energy of the atom and final kinetic energy of the electron.

GO ON TO THE NEXT PAGE.

Begin your response to **QUESTION 4** on this page.

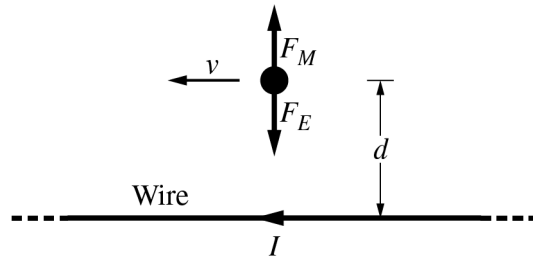

4. (10 points, suggested time 20 minutes)

At the instant shown above, a negatively charged object is moving to the left with constant velocity v near a long, straight wire that has a current I directed to the left. The region contains a uniform electric field of magnitude E , and the charged object is at a distance d from the wire. The figure shows the electric and magnetic forces, F_E and F_M , respectively, exerted on the charged object.

(a) Derive an expression for v in terms of E , d , I , and physical constants, as appropriate.

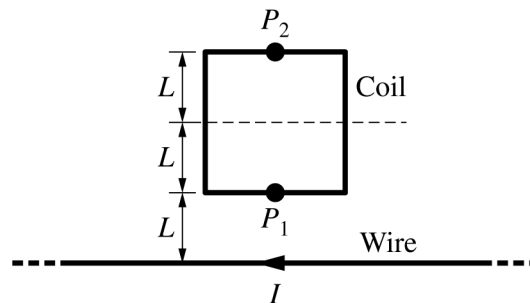

(b) The charged object is removed, and a square coil with side length $2L$ is placed near the long, straight wire, as shown above. The bottom of the coil is a distance L from the wire. The magnitude of the magnetic field due to the current in the wire is $3B_0$ at point P_1 and B_0 at point P_2 .

i. Write an “X” at a location on the figure where the magnitude of the magnetic field is $2B_0$. Briefly justify your reasoning.

GO ON TO THE NEXT PAGE.

Continue your response to **QUESTION 4** on this page.

- ii. Over a time interval of 2.0 s, the current in the wire is decreased. The initial magnetic flux through the coil is $5.0 \times 10^{-5} \text{ T}\cdot\text{m}^2$ and the final magnetic flux through the coil is $1.0 \times 10^{-5} \text{ T}\cdot\text{m}^2$. The coil has a total resistance of $10 \ \Omega$. Calculate the magnitude of the average current in the coil during the 2.0 s time interval.

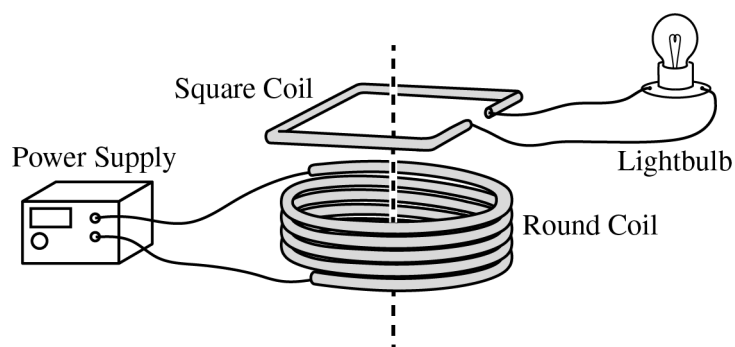

The wire is removed and the square coil is positioned so that the coil is directly above and concentric with a round coil of wire connected to a power supply. A part of the square coil is removed and a lightbulb is connected to the coil, as shown above.

- (c) During a short time interval, the current in the power supply is constantly increasing. Use physics principles to explain why the lightbulb is lit during the entire time interval.

GO ON TO THE NEXT PAGE.

STOP

END OF EXAM